

NEVADA OFF-HIGHWAY VEHICLES PROGRAM
Sumer 2022 GRANT APPLICATION
Nevada Commission on Off-Highway Vehicles
Nevada Department of Conservation and Natural Resources

This application has FIVE sections which are all REQUIRED to be filled out in full. To avoid disqualification, all application areas must be concise and complete; certifications must be signed and dated.

SECTION I - PROJECT AND APPLICANT INFORMATION

1. Project Name: Town of Tonopah OHV Staging Facility
2. Project Timeline: Fall 2022
3. Applicant Name: Nevada Offroad association for Town Of Tonopah

Mailing address: PO Box 1111 Carson City NV 89701

Phone: 775-430-0000

Email: Mathew@trailnv.com

4. Classification of Applicant: (check one)

- Federal State County Local/Municipal Other: _____
- Partnership Non-profit for Profit Individual

If the applicant is a corporate or legal entity, proof of good standing in the entity's state of incorporation is required. NAC 490.1345 (Note: grantees must have the capacity to implement and accomplish proposed project and properly administer awarded funds).



Applicant Signature
(Chairperson/President/Authorized Official)

Date 7/15/2022

5. Project Manager: Nevada Offroad Association – Mathew Giltner
Nevada Offroad association for Town Of Tonopah
PO Box 1111 Carson City NV 89701
Phone: 775-430-0000
Email: Mathew@trailnv.com

Alternate Contact: Joe Westerlund
Town Manager Town of Tonopah
140 South Main Street Tonopah, NV 89049
775-482-6643 - Office
E-mail - tpu.joe@gmail.com

6. Classification of Land Control: (check all that apply)

- Federally managed public land Private Land County City
 Other: Town of Tonopah
 Lease; Attach copy of lease with expiration date.
 R&PP; Attach copy of lease with expiration date.

7. Landowner: Town of Tonopah

140 South Main Street Tonopah, NV 89049
Phone: 775-482-6643 Email: tpu.joe@gmail.com

8. THE LANDOWNER MUST PROVIDE A LETTER STATING THAT:

Attached

- a) Landowner has read the Request for Grant Application package.
- b) Landowner agrees with the application and the terms of the grant.
- c) Landowner holds an interest in the subject land that is sufficient in scope and authority to allow the applicant to complete the proposed project and operate and maintain the proposed project after its completion.
- d) Landowner is legally committing to maintain the trail/facility and will allow public motorized access to such trail/facilities for 25 years or the normal life of the project; and
- e) Landowner agrees to provide any match or other tasks in the application that are assigned to Landowner.



Town of Tonopah
140 South Main Street
Post Office Box 151
Tonopah, Nevada 89049
Office (775) 482-6336
Fax (775) 482-3778
TDD: 711

30 June 2022

Nevada Off-Highway Vehicles Program
Department of Conservation and Natural Resources
901 S. Stewart Street, Ste 1003
Carson City, Nevada 89701

RE: Tonopah Fairgrounds OHV Staging Area.

Dear Commissioner's:

The above stated off-highway project has the approval of the Tonopah Town Board as of 30 June 2022.

The Board has read the Request for Grant Application package and attachments; and agree with the application and the terms of the grant. The Town of Tonopah is committed to maintaining the facility and will allow for motorized access to those facilities for 25 years or the normal life of the project, whichever is greater. The Board agrees to provide any match or other tasks in the application that are assigned to the Town of Tonopah

As a local government entity, the Tonopah Town Board holds the interest in the subject land that is sufficient in scope and authority to allow the applicant to complete the proposed project and operate and maintain the proposed project after its completion.

The project is located on local government land and is in conformance with the appropriate land management permits, licenses, clearances, and Federal environmental analyses documentation necessary to comply with local, state and/or federal laws specifically, NRS 490.069.

If you have any questions or concerns, please contact the Town Manager, Joe Westerlund at (775) 482-4308 or by email at tpu.joe@gmail.com.

Sincerely,

Don Kaminski, Chairman
Tonopah Town Board

www.TonopahNevada.com

The Town of Tonopah is an equal opportunity provider and employer.

9. PROJECT COSTS:

(grant request and matching funds directly related to the project)

State OHV Grant Request: 197,619.64
Matching Funds: **9935.00**
Total Project Amount : 207,554.64

What are the sources or Partners for your leveraged (matching) funds?

Federal Private In-kind City/County Other

Please describe additional funding source(s):

Following the stated desire of the OHV commission to award grants in phases providing a balance to the NVHOV grant funding this application is submitted acknowledging that tasking.
Matching Funds are from Nye County Public Works (earthwork) Town of Tonopah Public utilities (water, gates fencing subsequent maintenance, – Town/Surveyor engineer – platt map elevations and boundaries)

10. LETTERS OF SUPPORT FROM PARTNERS are required:

- a) Confirming they agree to the terms of the grant; and
- b) That they are committed to providing match/cash or other tasks in the application that are assigned to them.

Included in Permissions in line item 8, and at the end of this application

11. Project Type(s) (NRS 490.069 Sec.2c) check all that apply:

- X Studies or planning for trails and facilities.
 - o Environmental Assessments and Environmental Impact Studies.
 - o Other studies _____
- Acquisition of land for trails and facilities
- X Mapping and signing of trails and facilities
- Reconstruction, enhancement or maintenance of existing trails and facilities
- X Construction of new trails and facilities
- Restoration of areas that have been damaged by the use of off-highway vehicles.
- X The construction of trail features, trailheads, parking, or other ancillary facilities which minimize impacts to environmentally sensitive areas or important wildlife habitat areas.
- Safety training and education related to the use of off highway vehicles and registration
- Compliance and enforcement (See Appendix C, Enforcement Strategy example)

12. ALL TRAIL USERS: (check all that apply)

- | | | |
|---|---|--|
| <input type="checkbox"/> Mountain Biking | <input type="checkbox"/> Hiking/Backpacking | <input type="checkbox"/> Equestrian |
| <input checked="" type="checkbox"/> Single track motorcycle | <input type="checkbox"/> Snowmobiling | <input type="checkbox"/> Snowshoe/ski |
| <input checked="" type="checkbox"/> ATV quads | <input type="checkbox"/> Dune buggy | <input checked="" type="checkbox"/> UTV Side by side |
| <input checked="" type="checkbox"/> Race Course | <input type="checkbox"/> Skills riding course | |

The staging is part of a multi-use area for OHV, to access Public Lands in companion with Town of Tonopah and Nye County being an OHV friendly Community

13. Scope of Work: Please describe *exactly* what work will be completed. Programs, planning, NEPA, surveys, mapping, include miles of trail, trail type and other quantitative goals including a timeline for completing the work. NAC 490.1375. If purchase of equipment is included, please explain where/how it will be housed and maintained

In accordance with the NV OHV Grant Commission’s direction, this is a multi-phase project.

Phase One: Planning and Survey/engineering by Town of Tonopah(ToT). - **100% completed**

Phase Two: Excavation, gravel, gates, slope, and drainage ToT has secured commitment from Nye County – Water lines and hydrants to assist in reducing invasive species by ToT **50% completed**

Phase Three: Acquisition of kiosks, signage, sun shelters, vault toilet- **0% complete**

Maintenance of the staging area to be managed by Town of Tonopah after project is complete. Working through the Nevada Offroad Association, in partnership with Tread Lightly! for educational signage, as well as anticipation of the Nevada Outdoor School using this space for their youth OHV training program that has been embraced by the local community. Facility is ideal for registration drives and sheriffs OHV education outreach.

14. Standards/Guidelines that will be applied to your project:

- Universal Access to Outdoor Recreation - A Design Guide
- USFS Standard Specifications for Construction & Maintenance of Trails
- BLM Handbook 9114-1 Trails
- NOHVCC Handbooks

Other: NC ToT Public works and engineering department

15. Has the applicant received funding from the OHV Program in the past?

No **X Yes**

Nevada Offroad has received a grant, Town of Tonopah has not.

Number of projects funded: 2

Amount of funding Received: \$ 191815

Number of projects **Completed: 1 / Active: 1** – (Month 7.5 of 12)

SECTION II – LOCATION, MAPS, PHOTOS

Project Location:

County: NYE

Nearest Municipality/Town/City: Tonopah

Center of project: N38.07067, W117.19471

If the shape-files for the trail system are available, please submit them in the e-file. The shape-files of the trail will be required at project end. Program will assist in the collection of the data if needed.



Entrance Off US6

MAPS ARE A VERY IMPORTANT PART OF THE APPLICATION. THEY ARE REQUIRED AND CONSIDERED PART OF THE FINAL AGREEMENT IF FUNDED.

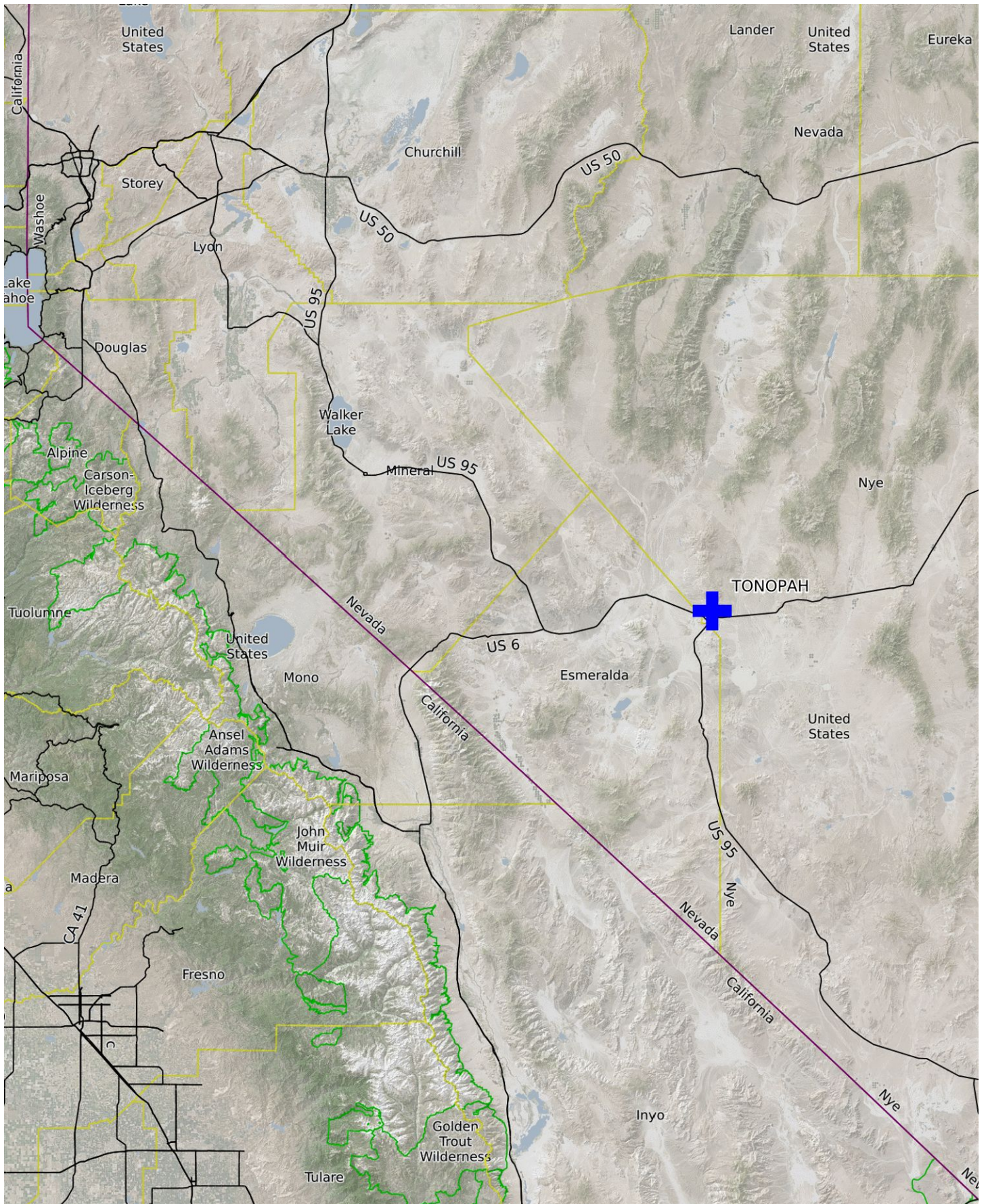

Mercator Projection
 WGS84
 UTM Zones 10S-11T
 CALTOPO

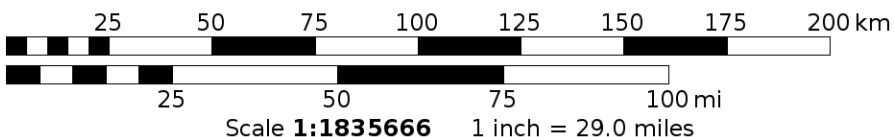

MN
 12.4°



OHV Staging Area

Mercator Projection
WGS84
UTM Zone 11S

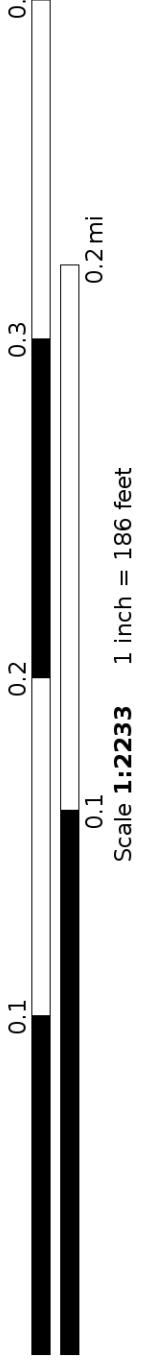
TOWN OF TONOPAH
RODEO GROUNDS
PROPERTY WITH
CONTOURS

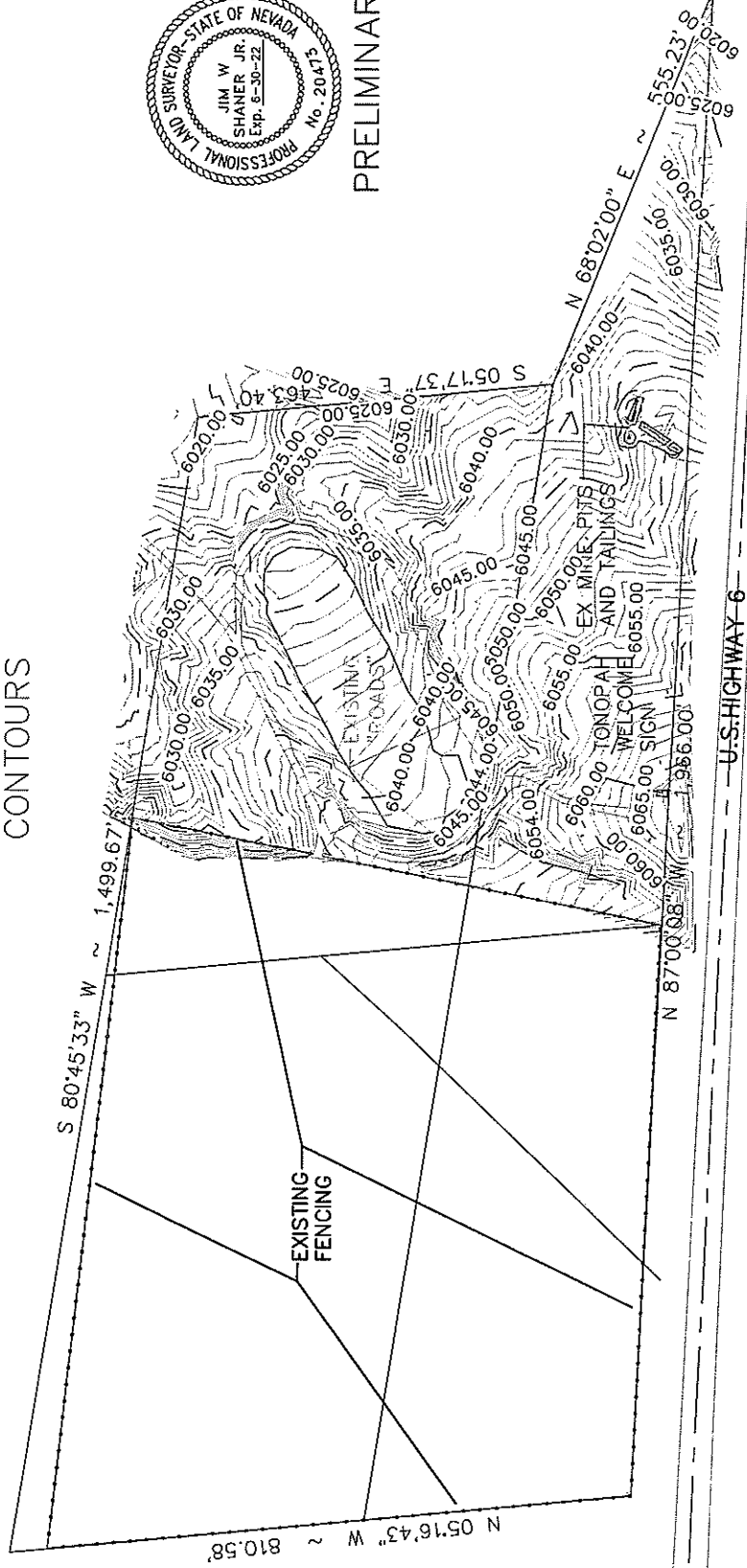

PRELIMINARY

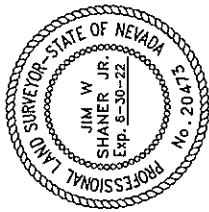

TOWN OF TONOPAH
RODEO GROUNDS
PROPERTY

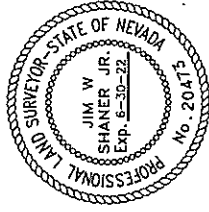
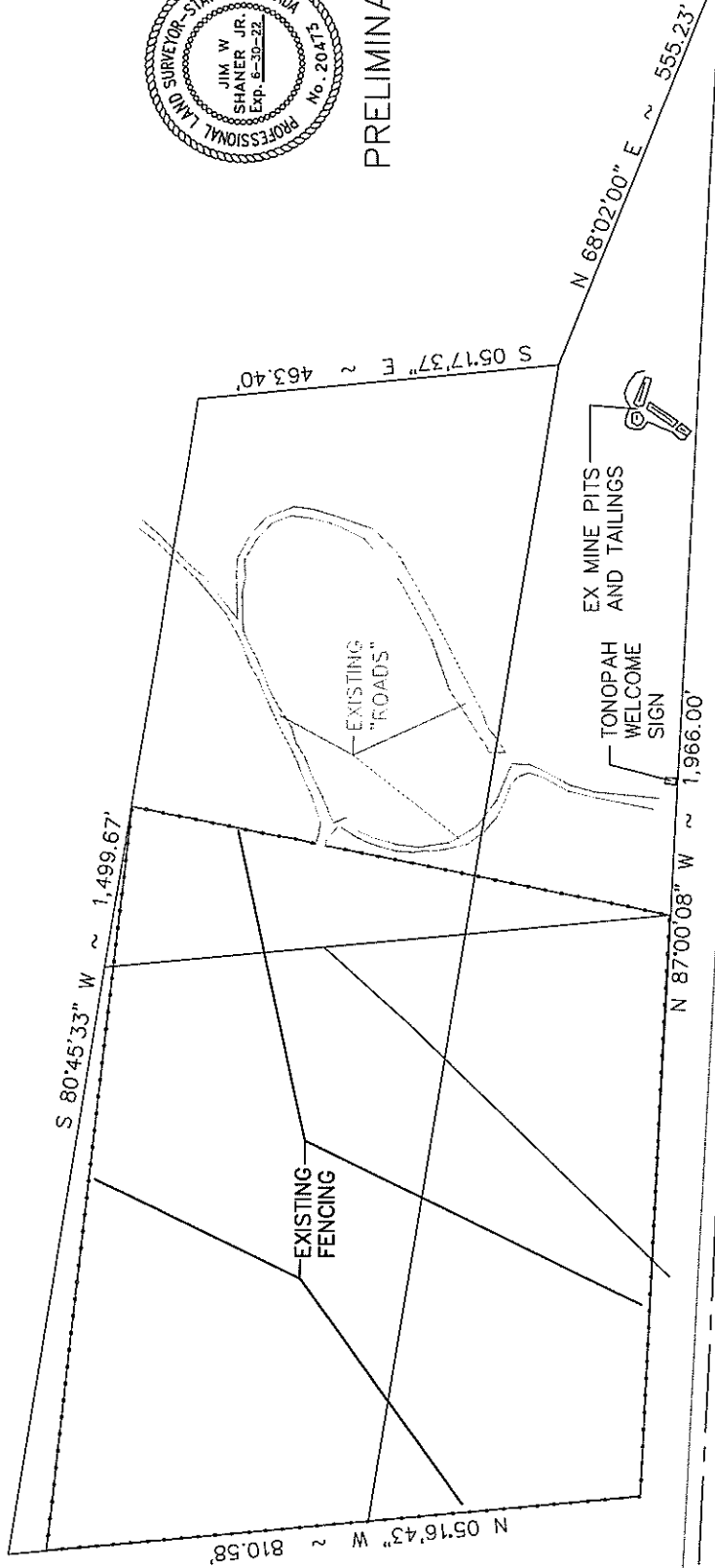

PRELIMINARY

U.S. HIGHWAY 6

Required Maps: for all maps, please include a legend, north arrow, scale, and map name.

Topographic maps preferred. You may include *additional* aerial/google maps.

X General location map (showing project area within the state or county)

X Detail map indicating specific project elements (e.g., structures, trail alignment)

- Maps larger than 11x17 will not be accepted

Please attach the following photographs:

X At least two (2) overviews of the project area from different angles and distances. (Good photographs at trail level and google aerials help the scoring committee to understand the location, depth and breadth of your project.)



Planned Vault Unit



Planned Shelter



SECTION III - Federal Lands or Other

Federal Environmental Compliance

A. If Federal funds or Land are a part of the project and NEPA was completed, indicate which document was produced, and **please attach the decision document to this application:**

- Record of Decision (ROD)
- Finding of No Significant Impact (FONSI)
- Categorical Exclusion (CX)
- SHPO 106 compliance/concurrence letter.
- Other compliance documents already completed. (do not attached the EA or EIS)
- Not applicable

If NEPA or planning is a part of the project describe the steps in the Scope Section I, #13.

SECTION IV - BUDGET

Proposed Budget: Provide your budget details to include at a minimum the items in the following table. You may create your own spreadsheet.

- Your budget must align clearly with your scope of work from #13. Be specific, as your application will rate higher.
- Reminder: Include all sources of funds for the completion of the project including federal, in-kind, private/city/county and state funds.
- **Attach copies of estimates to support your budget and identify what each contract will include.**

BUDGET

| Tonopah Fairground OHV Staging project | | | | |
|--|-----------------|---------------------|----------------------|-------------------------|
| Task/Item | Crew-Effort | Supplier | Cost - Grant Request | Cost - Inkind -Matching |
| Bathroom | Supplier | CTX - LB Foster | 62,800.00 | |
| Shade Structures/Kiosk | None | Big T Res | 65,439.64 | |
| Install Shade Structures/Kiosk | Contractor | G-Dubb Construction | 48,480.00 | |
| Excavation | Nye County | | | \$7,735.00 |
| Water Lines, Gate | Town of Tonopah | | | \$1,400.00 |
| Survey/engineering with drawings | Town of Tonopah | | | \$800.00 |
| Travel | | | 2,900.00 | |
| Adminstration Project Mgmt@10% | | 10% | 18,000.00 | |
| Totals | | | 197,619.64 | \$9,935.00 |

SECTION V – PRIORITIES AND SCORING NARRATIVE

Grants will be scored based on answers to the Ten (10) criteria listed below. Each criteria carries a weight determined by the OHV Commission, voted upon during the public meeting on 9/7/2021. Please reference scoring criteria form.

- 1. Law Enforcement Strategy that addresses registration enforcement, including Public Education & Outreach aimed at increasing renewals and new registrations:** This staging area affords Nye County Sheriff Office (NCSO) or other LEO a central location to provide outreach, education and registration events to OHV users. Additionally, the facility is available for OHV directed outreach events in northern Nye County by NCSO, BLM, or allied NGOs.
- 2. Enhancement or Maintenance of existing trails and facilities:** This project allows for a purpose-built access to public lands trails and routes. Kiosks will have mapping information on them as well as positive (Tread Lightly!) stewardship messaging.
- 3. Training:** this facility allows adequate space to host OHV training, including the Nevada Outdoor school's youth OHV program.
- 4. Trail mapping and signing of existing trails and facilities:** with installation of additional Kiosks and related signage, the facility will include maps from the Nevada mapping collaborative and will also be part of the Battle Born OHV route currently being planned from Pahrump to Virginia City.
- 5. Connectivity/Loops:** This facility is a central staging area along the western OHV routes, including the Battle Born route being identified from Pahrump to Virginia city. This area is adjacent to some of the competitive routes that have had the appropriate NEPA studies completed, and is an ideal staging point for riders who want to traverse the area both southerly to the Goldfield and Beatty areas as well as north to the newest OHV friendly community in Hawthorne Nevada.
- 6. Planning, Environmental Studies, Conservation:** like all purpose-built staging areas this reduced the damage caused by riders pulling off existing trails or roads to load and unload. With the addition of a vault toilet the reduction of human waste the environment is self-evident. ToT is installing water to the site to allow for riders to rinse off vehicles to reduce invasive weed transfer.
- 7. Access:** This part of northern Nye County does not have a purpose built staging area, having an area large enough to accommodate trailers to provide access to more than 7000 miles of OHV trails and roads will be an integral part of protecting OHV access.
- 8. Partnering and Leverage:** This project managed by the Nevada Offroad Association in partnership and with assistance of Tread Lightly!, the Town of Tonopah and Nye county .
- 9. Economic Integration:** This improvement is specifically targeting the tourist visit from Nevadans and those from the UT/CA/AZ riding communities. It allows for individuals to stay in town, with the opportunity to have a wide open staging area with the shade and sanitary facilities. Creating an ideal place to start and finish from. Additionally, when

groups are conducting offroad events, the economic input for the community is in the hundreds of thousands of dollars, in food fuel, and lodging. Having a well planned and suitable staging area adds significant value to any of these hosted events.

10. Demand for New Facilities: Northern Nye County has no formal OHV staging area. With the increase in OHV visitors, it is important we provide a quality staging area. As new facilities are created around Nevada, we are able to highlight the “OHV Friendly Communities, of which Tonopah, & Nye County already identify, and those communities can direct tourists to a safe well managed location to park and ride from.

SECRETARY OF STATE



DOMESTIC NONPROFIT CORPORATION (82) CHARTER

I, BARBARA K. CEGAVSKE, the duly qualified and elected Nevada Secretary of State, do hereby certify that **Nevada Offroad Association** did, on 06/28/2021, file in this office the original Articles of Incorporation-Nonprofit that said document is now on file and of record in the office of the Secretary of State of the State of Nevada, and further, that said document contains all the provisions required by the law of the State of Nevada.



Certificate
Number: B202106281784871
You may verify this certificate
online at <http://www.nvsos.gov>

IN WITNESS WHEREOF, I have hereunto set my hand and affixed the Great Seal of State, at my office on 06/28/2021.

Barbara K. Cegavske

BARBARA K. CEGAVSKE
Secretary of State



Date: July 4, 2022
To: Nevada Offroad Association
Re: Letter of Support for Nevada Offroad Association

To Whom It May Concern,

On behalf of Tread Lightly!, Inc., I am writing in support of the Nevada Offroad Association.

Nevada Offroad Association is seeking to build a designated OHV staging area, with supporting infrastructure in Tonopah, Nevada. Designated staging areas, such as this, provide a targeted location for public educational messaging through the T.R.E.A.D. principles. Creation of a designated location affords the user the opportunity to begin and end their day in the same spot. Locating a new staging area in an underserved rural community, like Tonopah, allows us to communicate and connect directly to rural communities often missed at larger events. Tread Lightly! believes that a well-managed, and maintained staging area is a tangible example of the results achieved from the positive stewardship values we work to promote.

The second grant we support is the continued operational funding request. Since before the Nevada Offroad Association was formalized and funded, their team has played a quality partnership role with Tread Lightly!. They have taken on a positive, results driven posture in addressing OHV use concerns in the past several years, notably in the Sweetwater mountains, Wilson Canyon, and the Pine Nut Mountains. Tread Lightly! has relied on the Nevada Offroad Association to fill in for our team at a Legacy Racing Association desert clean up day when our in house team unexpectedly was unable to coordinate that event. This cooperative posture is expanding their footprint statewide, and their synergistic relationship with the Tread Lightly! Nevada Program Manager continues to add value to the greater Nevada OHV community.

With an ever-growing and diverse population that desires outdoor recreation opportunities, it is increasingly more important to educate the public about ways to protect and conserve our public lands. NVORA has partnered with Tread Lightly! to provide up-to-date, consistent educational messages to the public in order to promote responsible and sustainable recreation activities on public lands and we believe that off-road motorsports provides a great medium for this communication.

Tread Lightly!'s educational programs, communications and tools provide consistent and specific messages geared toward the motorized recreation community. These messages will increase responsible behavior on roads and trails and help protect and conserve natural, cultural and historical resources.

Sincerely,

A handwritten signature in black ink, appearing to read "Matt Caldwell". The signature is fluid and cursive, with the first name "Matt" being more prominent than the last name "Caldwell".

Matt Caldwell
Executive Director
Tread Lightly!, Inc

July 14, 2022

To Whom it May Concern,

The Nevada Offroad Association is seeking to build a designated OHV staging area, with the supporting infrastructure in Tonopah NV.

Tonopah has taken a positive step to improve the youth educational environment for that community. The Nevada Outdoor School, through a recommendation from the Nevada Offroad Association was able to conduct an OHV safety youth education event for the first time in Nye County. The positive reaction to that event, resulted in the local leadership asking Nevada Outdoor School to make that training and outreach available annually.

By creating a staging area with bathrooms and shade structures provides an additional resource where we can conduct subsequent youth and adult training courses.

I encourage your support of this project.

Respectfully,

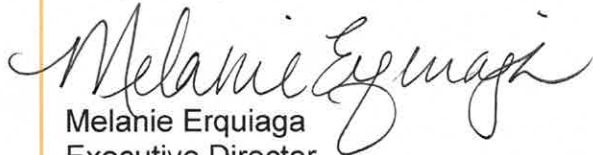

Melanie Erquiaga
Executive Director

Mathew Giltner

From: Gary Moody <gdubconstruction@gmail.com>
Sent: Wednesday, July 6, 2022 13:31
To: Mathew Giltner
Subject: Re: Hawthorne visit

Great meeting with you today. My preliminary number would be \$48,480.00. I can and will fine tune this but drawings would help a ton

Sent from my iPhone

On Jul 5, 2022, at 10:17 AM, Mathew Giltner <mathew@trailnv.com> wrote:

Gary,

I will be in Hawthorne tomorrow for the County Commission Meeting commission meeting, If you are available I would like to meet you and discuss the project we have going on at Tonopah.

Mathew.

*Mathew D. Giltner
Executive Director
Nevada Offroad Association
PO Box 1111
Carson City NV 89701
[775.430-0000](tel:775.430-0000)
nevadaoffroad.us
I Ride Nevada Responsibly*

Mathew Giltner

From: Joe Westerlund <tpu.joe@gmail.com>
Sent: Wednesday, June 8, 2022 07:05
To: Mathew Giltner
Subject: Nye County assistance

Hi Mathew, we were approved for the dirt work at the commissioners meeting yesterday for 7,735.00. So that should be the last piece of the puzzle on our end. Let me know if I can assist you with anything going forward. In anticipation of an award, do you think it might be productive to come up with a work schedule as far as what projects to start first?

Joe Westerlund

Town Manager
Town of Tonopah
140 South Main Street
PO Box 151
Tonopah, NV 89049
775-482-6643 - Office
775-482-4308 - Cell
775-482-3778 - Fax
E-mail - tpu.joe@gmail.com
<http://www.tonopahnevada.com>

Tioga Special

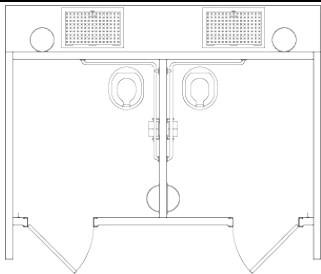

Tioga Special double vault. Standard features include two polyethylene lined concrete vaults, barnwood textured walls, cedar shake textured roof, off loaded and set up at site.

| Base Price | | Price per unit | Click to select |
|---|--|---|-----------------|
| Tioga Special 11' 11" x 14' 4" | | \$ | |
| Added Cost Options: | | | |
| Earth Work (includes excavation, backfill and cleanup) | | \$ | |
| Chase Option | | \$ | |
| Optional Wall Texture -choose one | Split Face Block (\$2,000) Struck Trowel (\$2,000) Stone (\$5,000) | | |
| Optional Roof Texture -choose one | Delta Rib | \$ | |
| Insulated Roof Panel (per room) | Qty: 2 | \$ | |
| Room Wastebasket (each) | Qty: 2 | \$ | |
| Stainless Steel Riser (each) | Qty: 2 | \$ | |
| Fiberglass Doors | | \$ | |
| Owl Guard (each) | Qty: 2 | \$ | |
| Hand Sanitizer (each) | | Qty: 2 | \$ |
| Marine Package for Extra Corrosion Resistance | | \$ | |
| Solar Light Kit (per room) | Qty: 2 | \$ | |
| Solar Fan Kit (per room) | Qty: 2 | \$ | |
| Rain Vent Cap (each) | Qty: 2 | \$ | |
| Timed Lock System (each) | Qty: 2 | \$ | |
| Conduit Junction Box (chase only) | | \$ | |
| Electric Light Package (chase only) | | \$ | |
| Total Cost of Selected Accessories from Accessories Price List: | | | \$ |
| Custom Options: | | | \$ |
| Engineering and State Fees: | | | \$ |
| Estimated One-way Transportation Costs to Site (quote): | | | \$ |
| Estimated Tax: | | | \$ |
| Estimated monthly payment on 5 year lease | | Total Cost per Unit Placed at Job Site: | \$ |

Other Options:

| | | | |
|--|-----------------------------|------------------------|---|
| Single Color: | Two-Tone Color: | *Signage: | Wall Vent Location:(upon entering door) |
| | Walls | Men Women | Right Side Rear |
| | Roof | Unisex Accessible | Left Side Door |
| <i>*Building includes restroom signs in Braille and roman lettering.</i> | | | |
| Top Section of Building: | Bottom Section of Building: | Rock Color Selection: | Notes: |
| Deadbolt Lock: | Door Opener: | Paper Holders: | |
| CXT Supplied | | | |
| Customer Supplied Lock | | | |

This price quote is good for 60 days from date below, and is accurate and complete.

CXT Sales Representative

Date

I accept this quote. Please process this order.

Company Name

Customer

Date



Big T Recreation
 11618 S. State St #1602
 Draper, UT 84020
 801-572-0782
 taft@bigtrec.com

QUOTE

| Date | Quote # |
|------------|------------|
| 05/16/2022 | 14948 |
| Exp. Date | |
| | 06/17/2022 |

| Shipping Address |
|---|
| Nevada Offroad Association PO Box 1111 Carson City NV 89701 |

| PRODUCT | DESCRIPTION | QTY | RATE | AMOUNT |
|-----------------|--|-----|-----------------|--------------------|
| Shade Structure | Tonopah Shade Structure & Kiosk AMERICANA OUTDOORS - ILLINI SHELTER Standard Frame Color, 20.000' x 30.000' (roof size) 4:12 Pitch, 8.000' eve height, 6 Surface Mount Posts, Tubular Steel Frame is Shot Blasted prior to Graffiti Cleanable Gloss or Non-Graffiti Cleanable Matte Powder Coat Finish, Structural Roof Panel Specs: 24 inches wide, Aluminum Material, .038 Thickness, Standard Color, Extruded Aluminum Gutter Fascia & Ridge Caps. | 2 | 20,755.00 | 41,510.00T |
| Shade Structure | AMERICANA OUTDOORS - CUSTMER COVER/WALKWAY 4 post structure, powder coated. to support three Bulletin Boards, double sided, enclosed, lockable, in Tonopah | 1 | 12,630.00 | 12,630.00T |
| Freight | Freight | 1 | 7,185.00 | 7,185.00 |
| | | | SUBTOTAL | 61,325.00 |
| | | | TAX | 4,114.64 |
| | | | TOTAL | \$65,439.64 |

Accepted By

Accepted Date

Acceptance of this quote agrees to the terms and conditions set by Big T Recreation. Please contact us with any questions or concerns P: 801.572.0782, F: 801.216.3077 or E: paul@bigTrec.com or merit@bigTrec.com.

We thank you for your business.

DOCUMENT NOT FOR CONSTRUCTION:

- A FOUNDATION DESIGN HAS NOT BEEN PERFORMED BY AMERICANA OUTDOORS
- A LICENSED ENGINEER FAMILIAR WITH SOIL CONDITIONS AT CONSTRUCTION SITE MUST PERFORM A FOUNDATION DESIGN

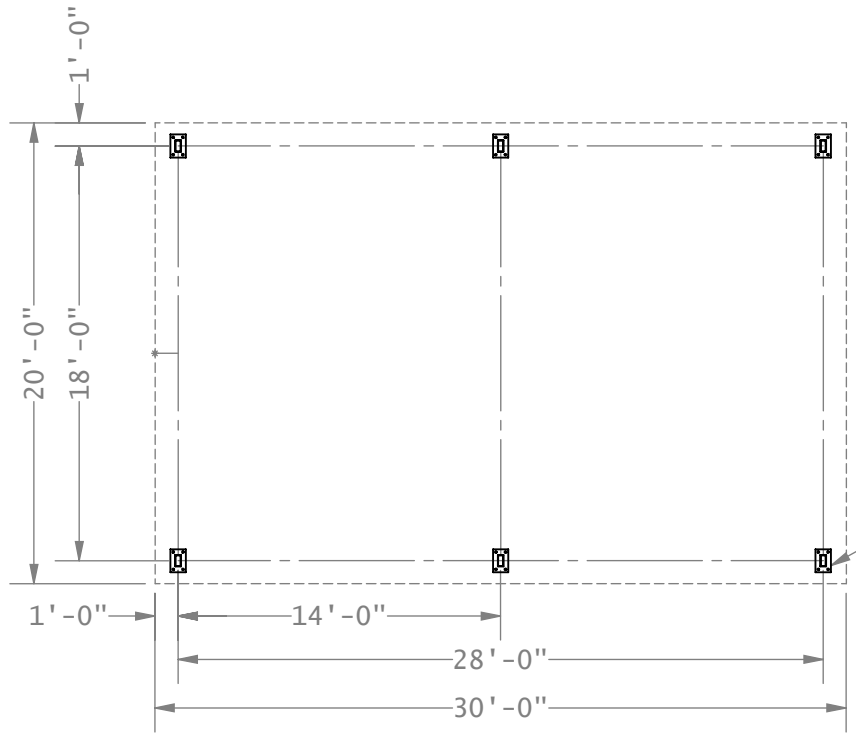
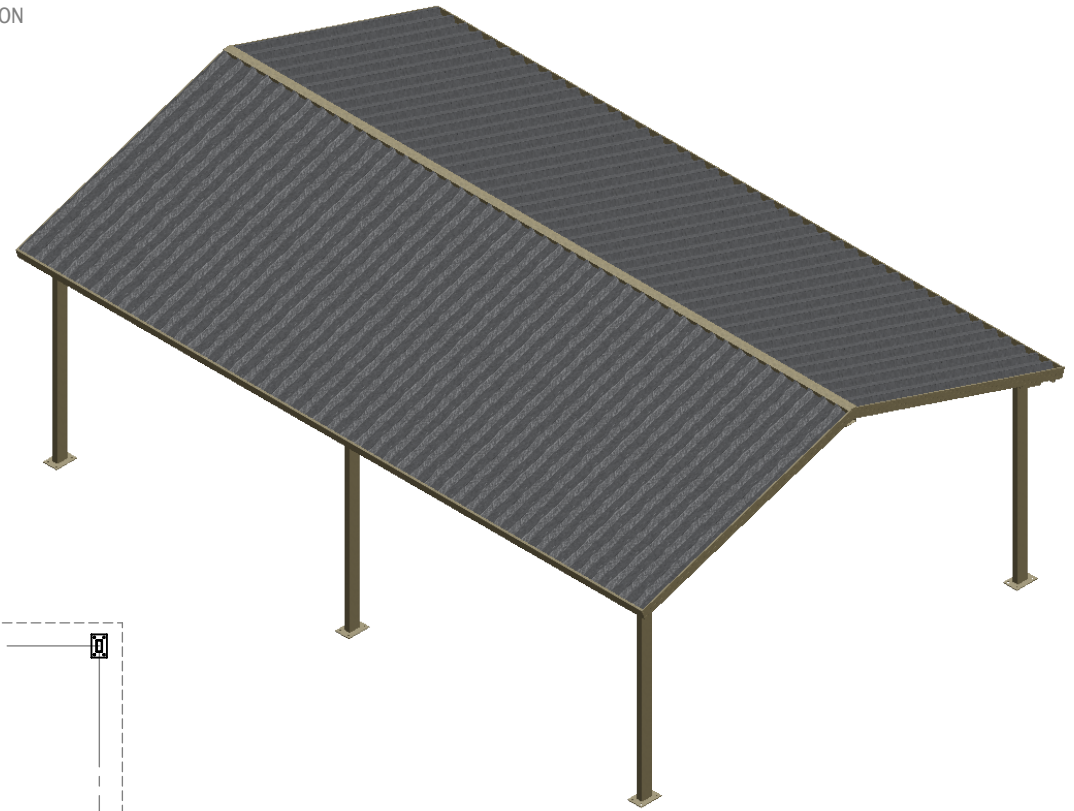

HSS STEEL POST
TYP. OF (6)

FOUNDATION PLAN

NOT FOR CONSTRUCTION



| | | | |
|----------|-----------|-----------------------------------|--------------|
| TITLE | | 20'-0" x 30'-0" ILLINI SHELTER | |
| SIZE | DATE | DWG NO | REV |
| A | 2/26/2022 | 98619 | |
| SCALE: | AS NOTED | DRAWN: MT | SHEET 1 of 2 |

(800) 851-0865
www.americana.com

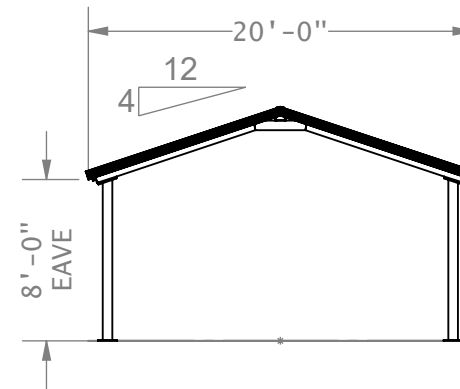
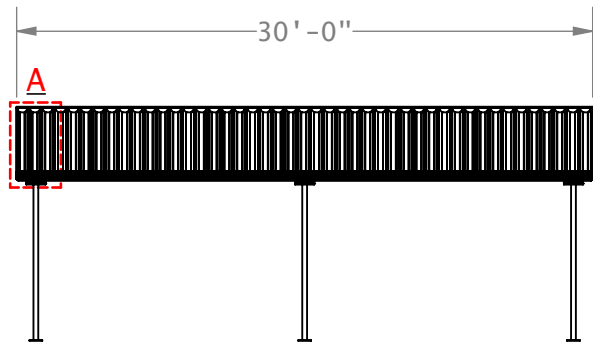

ELEVATION PLAN

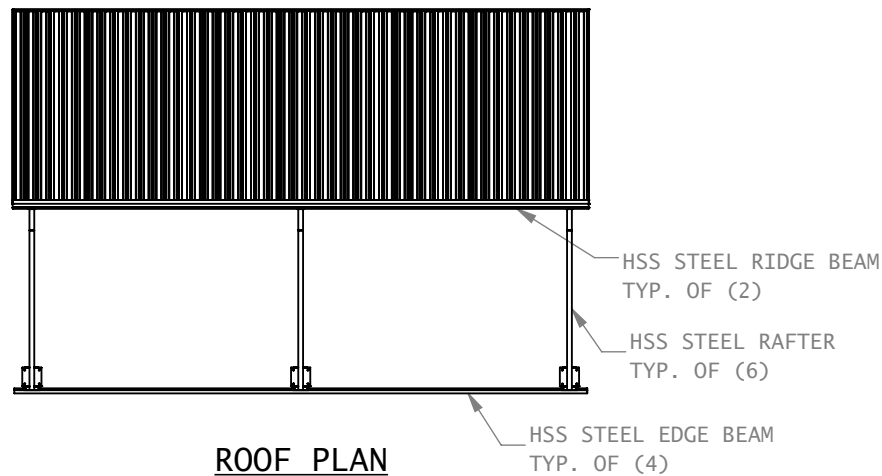

ROOF PLAN

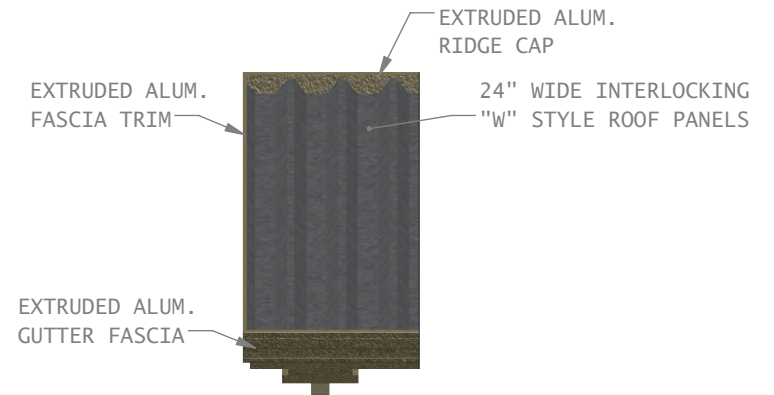

DETAIL A

| | | | |
|---|-----------|-----------|--------------|
|  | | | |
| TITLE 20'-0" x 30'-0" ILLINI SHELTER | | | |
| SIZE | DATE | DWG NO | REV |
| A | 2/26/2022 | 98619 | |
| SCALE: | AS NOTED | DRAWN: MT | SHEET 2 of 2 |

NOT FOR CONSTRUCTION

(800) 851-0865
www.americana.com

8 7 6 5 4 3 2 1

D

C

B

A

8 7 6 5 4 3 2 1

DOCUMENT NOT FOR CONSTRUCTION:

- A FOUNDATION DESIGN HAS NOT BEEN PERFORMED BY AMERICANA OUTDOORS
- A LICENSED ENGINEER FAMILIAR WITH SOIL CONDITIONS AT CONSTRUCTION SITE MUST PERFORM A FOUNDATION DESIGN

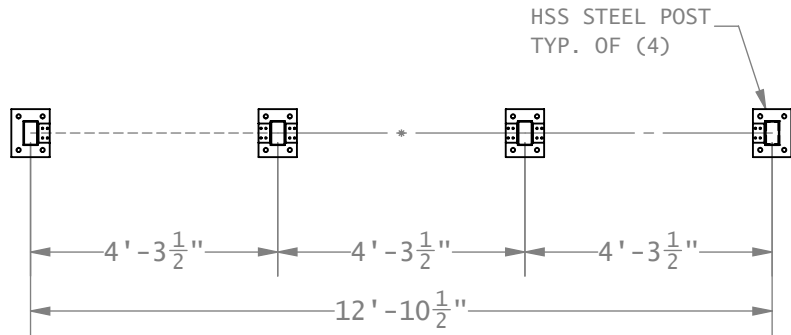

FOUNDATION PLAN

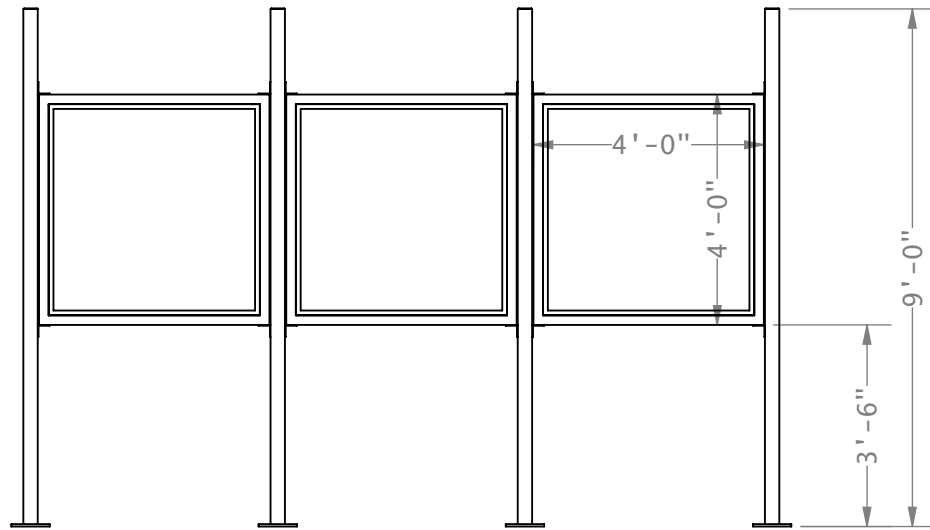

FRONT VIEW PLAN

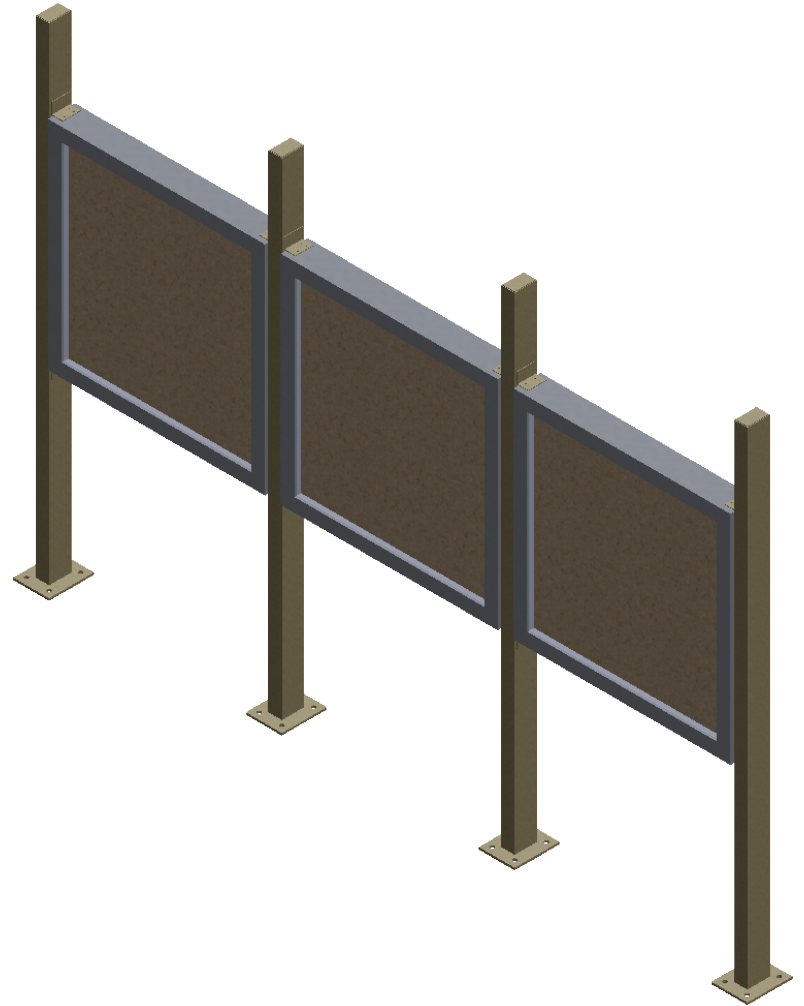

| | | | |
|---|-----------|-----------|--------------|
| TITLE | | | |
| 8'-0" x 8'-0" KIOSK CHEROKEE SHELTER | | | |
| SIZE | DATE | DWG NO | REV |
| A | 7/28/2021 | 94463-2 | |
| SCALE: | AS NOTED | DRAWN: MT | SHEET 1 of 1 |

NOT FOR CONSTRUCTION